

# Montageanleitung

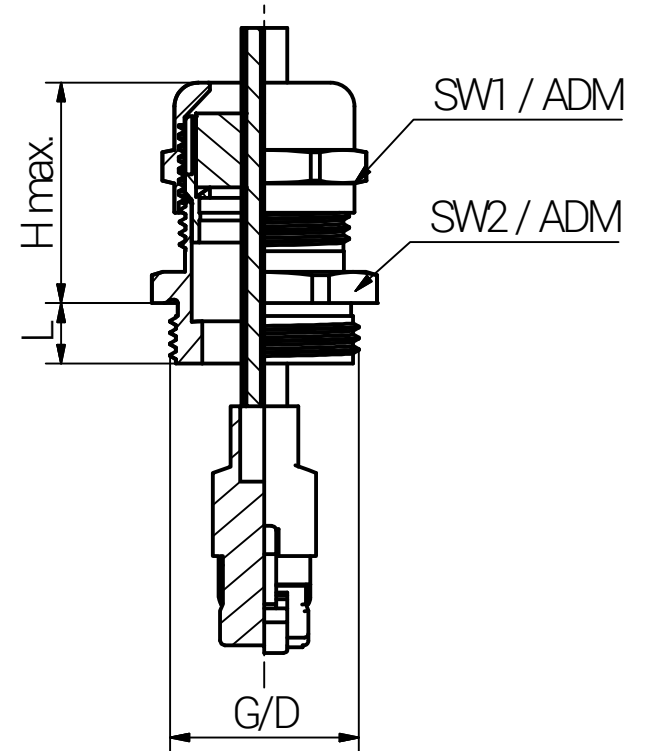
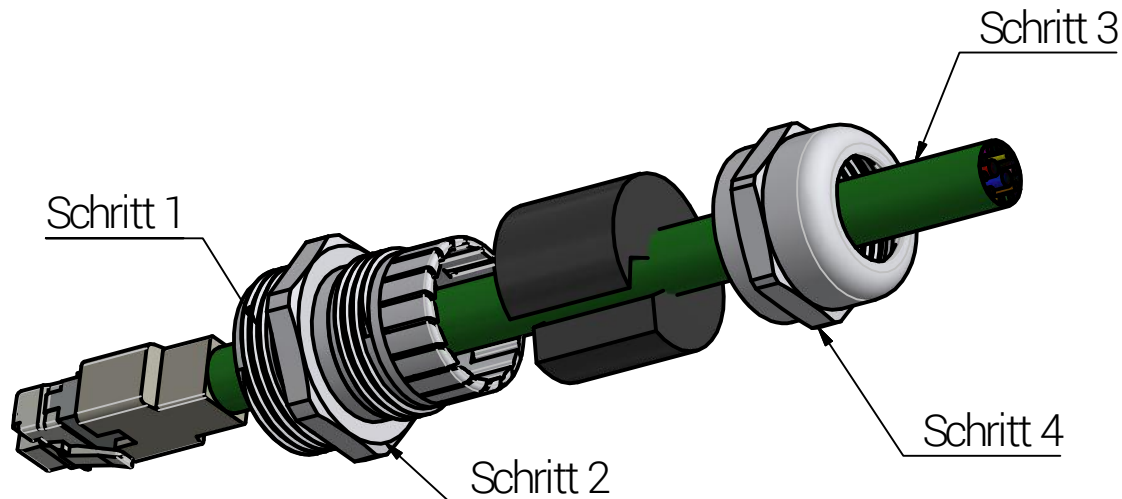

Schritt	Montageschritt (Die Installation sollte nur von einem qualifizierten Elektriker durchgeführt werden, der in der Installation von Kabelverschraubungen geschult ist.)	Artikel		Gewinde G	Klemmbereich (mm)		SW1 (mm)	SW2 (mm)	L (mm)	H max. (mm)	Durchgangs- bohrung D (mm)	Anzugsdreh- moment (Nm) ADM	
		MS	1.4305		≥	≤						Hutmutter	Stützen
1	Kabelverschraubung mit dem Anschlussgewinde am Gegenstück (z.B. Elektronikgehäuse) montieren.			M32x1,5	3,0	6,0	30	34	9,0	33,0	32 (0/+0,2)	20,0	6,0
2	Stützen soweit anziehen, dass der O-Ring seine Funktion erfüllt. Zu festes Anziehen kann zu Beschädigungen führen.			M32x1,5	3,0	6,0	30	36	9,0	41,5	32 (0/+0,2)	20,0	6,0
3	Kabel durch die Kabelverschraubungen führen.												
4	Hutmutter soweit anziehen, dass der Dichteinsatz seine Funktion erfüllt. Zu festes Anziehen kann zu Beschädigungen führen.												
Durchmesser des Montagelochs: - Gewindebohrung gemäß EN 60423 - Durchgangsbohrung siehe Tabelle.													
IP-Schutzart ist IP 68 (5 bar / 30 min.) / IP 66 / IP 69k.													
Einsatztemperatur: -20°C bis +100°C													

	RST Rabe-System-Technik und Vertriebs-GmbH Otto-Lilienthal-Strasse 19 49134 Wallenhorst ☎ +49 5407 8766-0 📠 +49 5407 8766-99 ✉ info@rst.eu			Unless otherwise specified on the drawing: Metric Thread = EN 60423 PG Thread = DIN 40430 NPT Thread = ANSI B1.20.1 Tolerance: DIN ISO 2768-m All dimensions in mm.			Abusively use, in particular reproduction and dissemination to third parties is not permitted. You can be punished by civil law. Technical changes are reserved.			
				Date	Name					
			Draw.	29.10.2020	SL	<h2 style="text-align: center;">Euro-Top CONNECT Metall Metrisch</h2>				
			Appr.	29.10.2020	KH					
			Norm							
			Scale:		1:1					
			Material:	Messing, vern. / Edelstahl		Drawing-Nr.:	x0580532_SZM_TD_German		1	of 1
		A	Anzugsdrehmoment	10.05.2021	SL			A4		
		Status	Modification	Date	Name	Z:\Inventar\Montageanleitung\Euro-Top-Connect\ET-Connect-Metall-x0580532_SZM_TD_German.idw				V10

Bitte beachten Sie, dass es sich bei der o.a. Darstellung nur um ein Maßbild handelt.

# Mounting Instruction

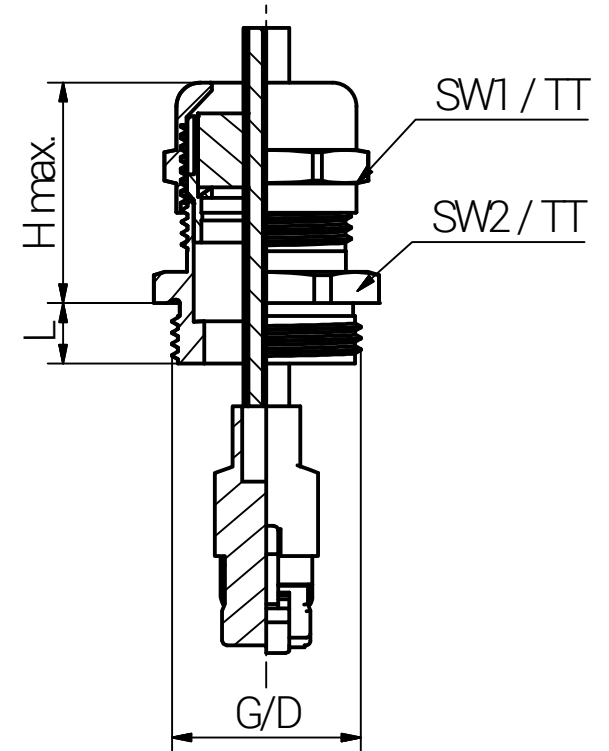
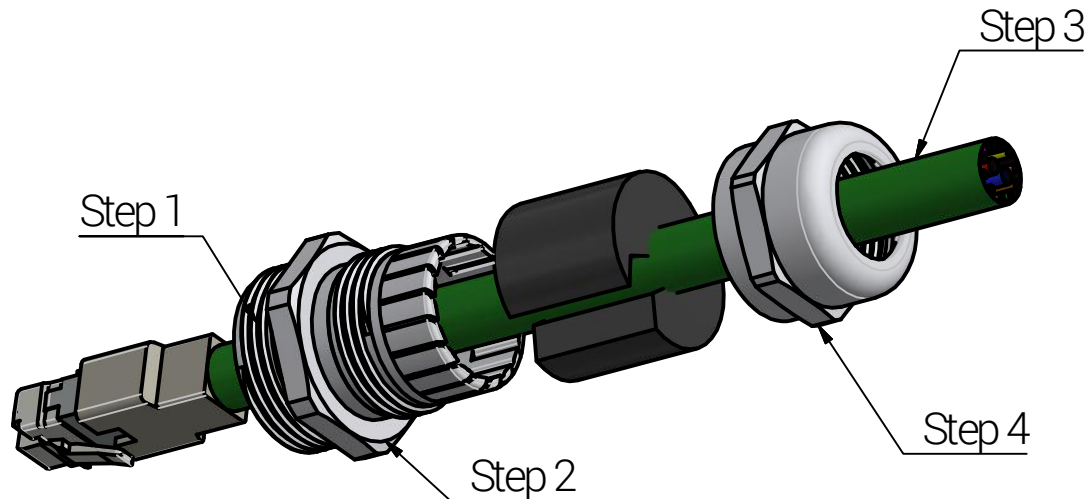

Step	Assembly Steps (The installation should only be done by a qualified electrician who are trained in the installation of cable glands.)
1	Mount the cable gland with the connection thread on the counterpart (e.g. electronic enclosure).
2	Tighten the body until the O-Ring fulfills its function. Over tightening may cause damage.
3	Pass the cable through the cable gland.
4	Tighten the cap until the seal fulfills its function. Over tightening may cause damage.
Diameter of the mounting hole: - Threaded hole according to EN 60423 - Through hole see table.	
Protection Class: IP 68 (5 bar / 30 min.) / IP 66 / IP 69k	
Operating Temperature: -20°C to +100°C	

Article		Thread	Clamping Range (mm)		SW1 (mm)	SW2 (mm)	L (mm)	H max. (mm)	Non Threaded Enclosure D (mm)	Tightening Torque (Nm) TT	
BR	303	G	≥	≤					Cap	Body	
60580532		M32x1,5	3,0	6,0	30	34	9,0	33,0	32 (0/+0,2)	20,0	6,0
	90580532	M32x1,5	3,0	6,0	30	36	9,0	41,5	32 (0/+0,2)	20,0	6,0



RST Rabe-System-Technik und Vertriebs-GmbH  
Otto-Lilienthal-Strasse 19  
49134 Wallenhorst  
☎ +49 5407 8766-0  
☎ +49 5407 8766-99  
✉ info@rst.eu

Unless otherwise specified on the drawing:  
Metric Thread = EN 60423  
PG Thread = DIN 40430  
NPT Thread = ANSI B1.20.1  
Tolerance: DIN ISO 2768-m  
All dimensions in mm.

Abusively use, in particular reproduction and dissemination to third parties is not permitted. You can be punished by civil law. Technical changes are reserved.

		Date	Name
Draw.	29.10.2020	SL	
Appr.	29.10.2020	KH	
Norm			
Scale:		1:1	
Material:		Nickel Plated Brass / Stainless Steel	
A	Tightening Torque	10.05.2021	SL
Status	Modification	Date	Name

## Euro-Top CONNECT Metal Metric

Drawing-Nr.:	<b>x0580532_SZM_TD_English</b>	<b>1</b>	of 1
		A4	
		V7	

Please note that the above representation is just a dimension illustration.