

# Montageanleitung

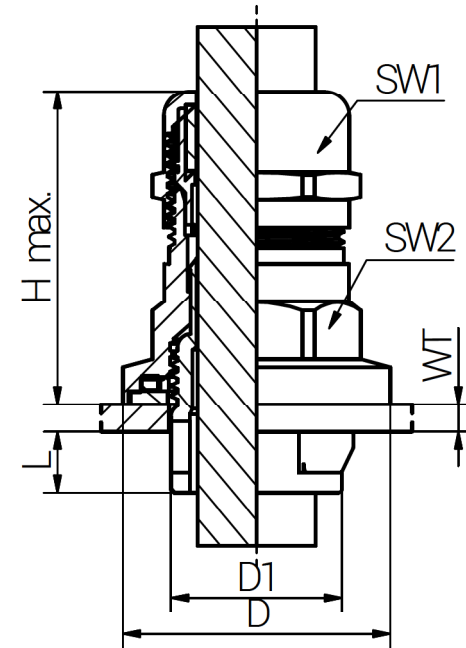

Artikel	Größe	Klemmbe- reich (mm)		Gehäuse- wand- stärke WT (mm)	SW1 (mm)	SW2 (mm)	L (mm)	D (mm)	D1 (mm)	H max. (mm)	Durchgangs- bohrung D (mm)
		≥	≤								
FRONTFIX6016	M16	5,0	10,0	0,5 - 4,0	20	20	90	28,3	16,0	45,0	16,2-16,4
FRONTFIX6020	M20	6,0	12,0	0,5 - 4,0	22	22	90	32,3	20,0	44,0	20,2-20,4
FRONTFIX6025	M25	11,0	17,0	0,5 - 4,0	27	27	90	38,5	25,0	46,0	25,2-25,4
FRONTFIX6032	M32	15,0	21,0	0,5 - 4,0	34	34	90	45,5	32,0	54,0	32,2-32,4
FRONTFIX6040	M40	19,0	28,0	0,5 - 4,0	43	43	13,2	58,0	40,0	60,0	40,2-40,4

Schritt	Montageschritt (Die Installation sollte nur von einem qualifizierten Elektriker durchgeführt werden, der in der Installation von Kabelverschraubungen geschult ist.)
1	Kabelverschraubung mit dem Schnellmontage-Anschlussstutzen am Gegenstück (z.B. Elektronikgehäuse) einführen und bis einrasten andrücken.
2	Stutzen soweit anziehen, dass die Flachdichtung ihre Funktion erfüllt. Zu festes Anziehen kann zu Beschädigungen führen.
3	Kabel durch die Kabelverschraubungen führen.
4	Hutmutter soweit anziehen, dass der Dichteinsatz seine Funktion erfüllt. Zu festes Anziehen kann zu Beschädigungen führen.
Durchmesser des Montagelochs: - Durchgangsbohrung siehe Tabelle.	
IP-Schutzart ist IP 68 (5 bar / 30 min.) / IP 66.	
Einsatztemperatur: -20°C bis + 100°C kurzfristig bis +150°C.	

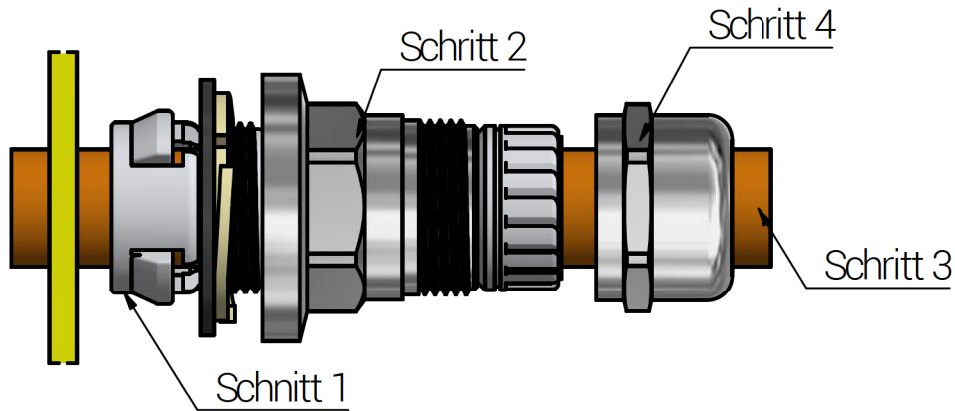

RST Rabe-System-Technik und Vertriebs-GmbH  
 Otto-Illenthal-Strasse 19  
 49134 Wallenhorst  
 ☎ +49 5407 8765-0  
 ☎ +49 5407 8765-99  
 ✉ info@rst.eu

Unless otherwise specified on the drawing:  
 Metric Thread = EN 60423  
 PG Thread = DIN 40430  
 NPT Thread = ANSI B1.20.1  
 Tolerance: DIN ISO 2768-m  
 All dimensions in mm.

Abusive use, in particular reproduction and dissemination to third parties is not permitted. You can be punished by civil law. Technical changes are reserved.

Date	Name
Draw. 29.10.2020	SL
Appr. 29.10.2020	KH
Norm	
Scale:	1:1
Material:	Messing, vernickelt
Status	Modification
Date	Name

<h2>Euro-Top FRONTFIX MS</h2>	
Drawing-Nr.:	FRONTFIX60xx_SZM_TD_German
	1 of 1
	A4
	V20

Bitte beachten Sie, dass es sich bei der o.a. Darstellung nur um ein Maßbild handelt.

# Montageanleitung

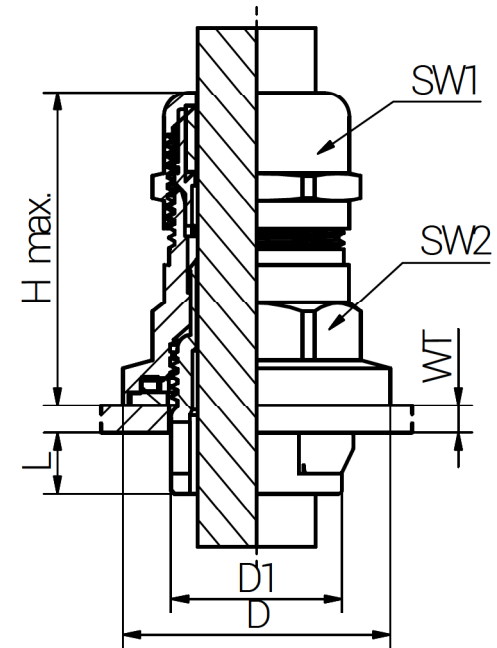
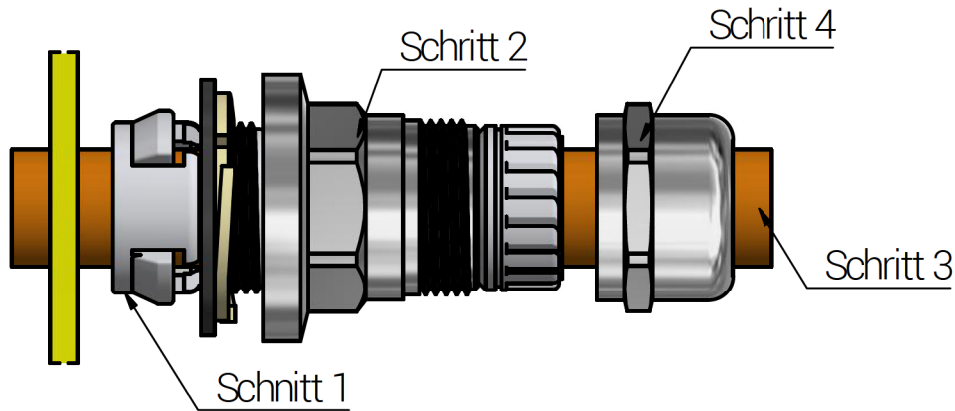

Artikel	Größe	Klemmbe- reich (mm)		Gehäuse- wand- stärke WT (mm)	SW1 (mm)	SW2 (mm)	L (mm)	D (mm)	D1 (mm)	H max. (mm)	Durchgangs- bohrung D (mm)
		≥	≤								
FRONTFIX6016R	M16	3,0	7,0	0,5 - 4,0	20	20	9,0	28,3	16,0	45,0	16,2-16,4
FRONTFIX6020R	M20	5,0	9,0	0,5 - 4,0	22	22	9,0	32,3	20,0	44,0	20,2-20,4
FRONTFIX6025R	M25	9,0	13,0	0,5 - 4,0	27	27	9,0	38,5	25,0	46,0	25,2-25,4
FRONTFIX6032R	M32	11,0	15,0	0,5 - 4,0	34	34	9,0	45,5	32,0	54,0	32,2-32,4
FRONTFIX6040R	M40	16,0	23,0	0,5 - 4,0	43	43	13,2	58,0	40,0	60,0	40,2-40,4

Schritt	Montageschritt (Die Installation sollte nur von einem qualifizierten Elektriker durchgeführt werden, der in der Installation von Kabelverschraubungen geschult ist.)
1	Kabelverschraubung mit dem Schnellmontage-Anschlussstutzen am Gegenstück (z.B. Elektronikgehäuse) einführen und bis einrasten andrücken.
2	Stutzen soweit anziehen, dass die Flachdichtung ihre Funktion erfüllt. Zu festes Anziehen kann zu Beschädigungen führen.
3	Kabel durch die Kabelverschraubungen führen.
4	Hutmutter soweit anziehen, dass der Dichteinsatz seine Funktion erfüllt. Zu festes Anziehen kann zu Beschädigungen führen.
Durchmesser des Montagelochs: - Durchgangsbohrung siehe Tabelle.	
IP-Schutzart ist IP 68 (5 bar / 30 min.) / IP 66.	
Einsatztemperatur: -20°C bis +100°C kurzfristig bis +150°C.	



RST Rabe-System-Technik und Vertriebs-GmbH  
 Otto-Lilienthal-Strasse 19  
 49134 Wallenhorst  
 ☎ +49 5407 8765-0  
 ☎ +49 5407 8765-99  
 ✉ info@rst.eu

Unless otherwise specified on the drawing:  
 Metric Thread = EN 60423  
 PG Thread = DIN 40430  
 NPT Thread = ANSI B1.20.1  
 Tolerance: DIN ISO 2768-m  
 All dimensions in mm.

Abusive use, in particular reproduction and dissemination to third parties is not permitted. You can be punished by civil law. Technical changes are reserved.

Date	Name
Draw. 29.10.2020	SL
Appr. 29.10.2020	KH
Norm	
Scale:	1:1
Material:	Messing, vernickelt
Status	Modification
Date	Name

<b>Euro-Top FRONTFIX MS mit Reduzierdichteinsatz</b>		
Drawing-Nr.:	FRONTFIX60xxR_SZM_TD_German	1 of 1
		A4
		V6

Bitte beachten Sie, dass es sich bei der o.a. Darstellung nur um ein Maßbild handelt.

# Mounting Instruction

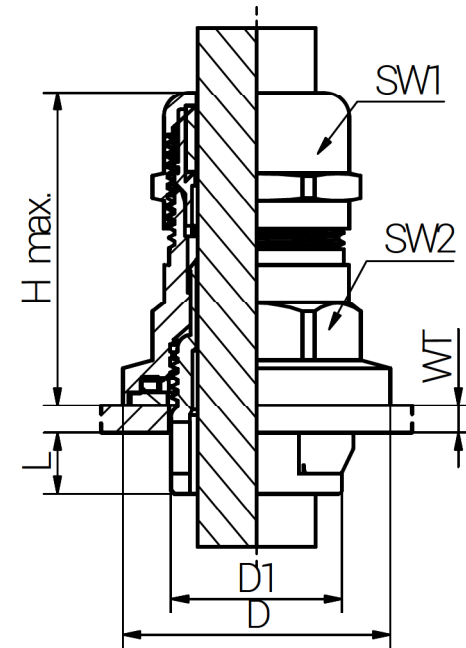
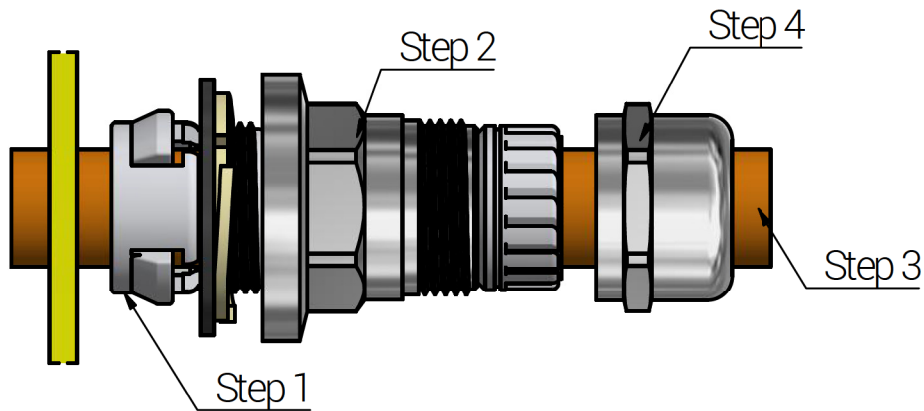

Article	Size	Clamping Range (mm)		Enclosure Wall Thickness WT (mm)	SW1 (mm)	SW2 (mm)	L (mm)	D (mm)	D1 (mm)	H max. (mm)	Non Threaded Enclosure D (mm)
		≥	≤								
FRONTFIX6016	M16	5,0	10,0	0,5 - 4,0	20	20	9,0	28,3	16,0	45,0	16,2-16,4
FRONTFIX6020	M20	6,0	12,0	0,5 - 4,0	22	22	9,0	32,3	20,0	44,0	20,2-20,4
FRONTFIX6025	M25	11,0	17,0	0,5 - 4,0	27	27	9,0	38,5	25,0	46,0	25,2-25,4
FRONTFIX6032	M32	15,0	21,0	0,5 - 4,0	34	34	9,0	45,5	32,0	54,0	32,2-32,4
FRONTFIX6040	M40	19,0	28,0	0,5 - 4,0	43	43	13,2	58,0	40,0	60,0	40,2-40,4

Step	Assembly Steps (The installation should only be done by a qualified electrician who are trained in the installation of cable glands.)
1	Push in the cable gland using the quick-assembly body on the counterpart (e.g. electronic enclosure) and press until it clicks into place.
2	Tighten the body until the sealing washer fulfills its function. Over tightening may cause damage.
3	Pass the cable through the cable gland.
4	Tighten the cap until the seal fulfills its function. Over tightening may cause damage.
Diameter of the mounting hole: - Through hole see table.	
Protection Class: IP 68 (5 bar / 30 min.) / IP 66.	
Operating Temperature: -20°C to +100°C intermittent up +150°C.	



RST Rabe-System-Technik und Vertriebs-GmbH  
 Otto-Hilfenhof-Strasse 19  
 49134 Wallenhorst  
 ☎ +49 5407 8765-0  
 📠 +49 5407 8765-99  
 ✉ info@rst.eu

Unless otherwise specified on the drawing:  
 Metric Thread = EN 60423  
 PG Thread = DIN 40430  
 NPT Thread = ANSI B1.20.1  
 Tolerance: DIN ISO 2768-m  
 All dimensions in mm.

Abusive use, in particular reproduction and dissemination to third parties is not permitted. You can be punished by civil law. Technical changes are reserved.

Date	Name
Draw. 29.10.2020	SL
Appr. 29.10.2020	KH
Norm	
Scale:	1:1
Material:	Nickel Plated Brass
Status	Modification
Date	Name

<h2>Euro-Top FRONTFIX MS</h2>	
Drawing-Nr.:	FRONTFIX60xx_SZM_TD_English
	1 of 1
	A4
	V7

Please note that the above representation is just a dimension illustration.

# Mounting Instruction

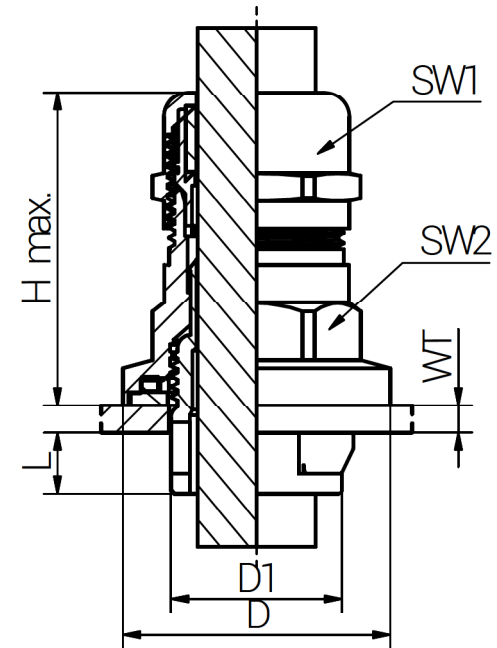
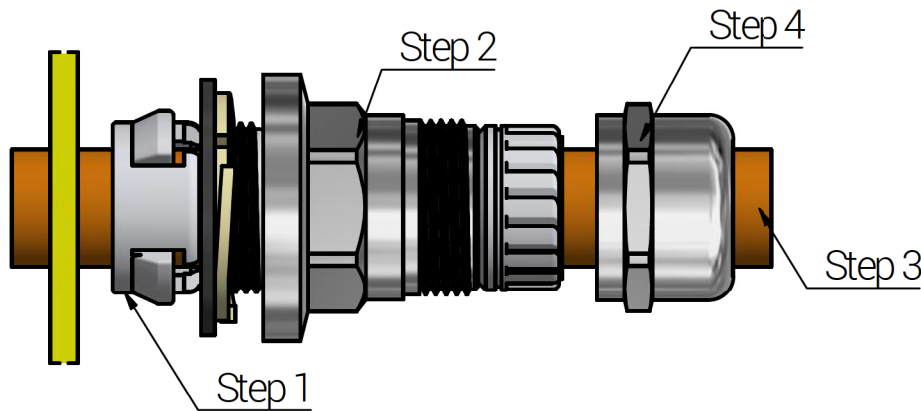

Article	Size	Clamping Range (mm)		Enclosure Wall Thickness WT (mm)	SW1 (mm)	SW2 (mm)	L (mm)	D (mm)	D1 (mm)	H max. (mm)	Non Threaded Enclosure D (mm)
		≥	≤								
FRONTFIX6016R	M16	3,0	7,0	0,5 - 4,0	20	20	9,0	28,3	16,0	45,0	16,2-16,4
FRONTFIX6020R	M20	5,0	9,0	0,5 - 4,0	22	22	9,0	32,3	20,0	44,0	20,2-20,4
FRONTFIX6025R	M25	9,0	13,0	0,5 - 4,0	27	27	9,0	38,5	25,0	46,0	25,2-25,4
FRONTFIX6032R	M32	11,0	15,0	0,5 - 4,0	34	34	9,0	45,5	32,0	54,0	32,2-32,4
FRONTFIX6040R	M40	16,0	23,0	0,5 - 4,0	43	43	13,2	58,0	40,0	60,0	40,2-40,4

Step	Assembly Steps (The installation should only be done by a qualified electrician who are trained in the installation of cable glands.)
1	Push in the cable gland using the quick-assembly body on the counterpart (e.g. electronic enclosure) and press until it clicks into place.
2	Tighten the body until the sealing washer fulfills its function. Over tightening may cause damage.
3	Pass the cable through the cable gland.
4	Tighten the cap until the seal fulfills its function. Over tightening may cause damage.
Diameter of the mounting hole: - Through hole see table.	
Protection Class: IP 68 (5 bar / 30 min.) / IP 66.	
Operating Temperature: -20°C to +100°C intermittent up +150°C.	

		RST Rabe-System-Technik und Vertriebs-GmbH Otto-Hilgenhof-Strasse 19 49134 Wallenhorst ☎ +49 5407 8765-0 📠 +49 5407 8765-99 📧 info@rst.eu		Unless otherwise specified on the drawing: Metric Thread = EN 60423 PG Thread = DIN 40430 NPT Thread = ANSI B1.20.1 Tolerance: DIN ISO 2768-m All dimensions in mm.		Abusive use, in particular reproduction and dissemination to third parties is not permitted. You can be punished by civil law. Technical changes are reserved.	
		Draw.		29.10.2020		SL	
		Appr.		29.10.2020		KH	
		Norm					
		Scale:				1:1	
		Material:		Nickel Plated Brass		Drawing-Nr.: FRONTFIX60xxR_SZM_TD_English	
Status		Modification		Date		Name	
				Z:\Inventar\Montageanleitung\Euro-Top-FRONTFIX\Messing\FRONTFIX-MS-FRONTFIX60xxR_SZM_TD_English.idw		1 of 1	
						A4	
						V6	

## Euro-Top FRONTFIX MS with Reducing Sealing

Please note that the above representation is just a dimension illustration.