

Montageanleitung

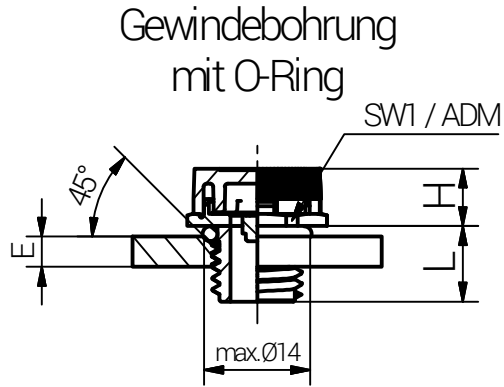

E= Min. 4,0 mm
O-Ring

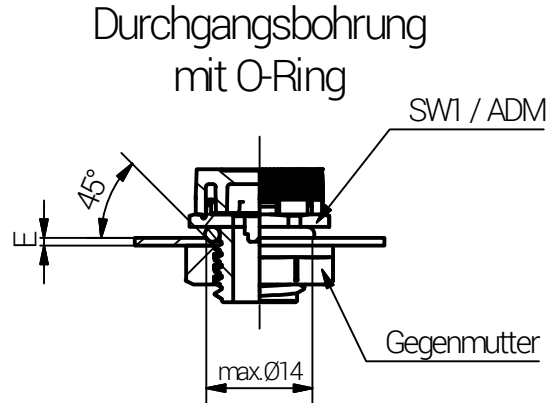

E= Max. 1,0 mm für 6,0 mm Gewindelänge
E= Max. 5,0 mm für 10,0 mm Gewindelänge

Schritt	Montageschritt (Die Installation sollte nur von einem qualifizierten Elektriker durchgeführt werden, der in der Installation von Kabelverschraubungen geschult ist.)
1	Druckausgleichselement mit dem Anschlussgewinde am Gegenstück (z.B. Elektronikgehäuse) montieren und so weit anziehen, dass der O-Ring seine Funktion erfüllt. Zu festes Anziehen kann zu Beschädigungen führen. Das Druckausgleichselement sollte seitlich montiert werden.

Artikel	Membran-typ	Gewinde	SW1	L	H max.	Anzugsdrehmoment (Nm) ADM
RAL7035	RAL9005	G	(mm)	(mm)	(mm)	Toleranz ±0,1
11086512HLD	13086512HLD	H	M12x1,5	17	6,0	7,6
11087512HLD	13087512HLD	H	M12x1,5	17	10,0	7,6



RST Rabe-System-Technik und Vertriebs-GmbH
Otto-Lilienthal-Strasse 19
49134 Wallenhorst
☎ +49 5407 8766-0
☎ +49 5407 8766-99
✉ info@rst.eu

Unless otherwise specified on the drawing:
Metric Thread = EN 60423
PG Thread = DIN 40430
NPT Thread = ANSI B1.20.1
Tolerance: DIN ISO 2768-m
All dimensions in mm

Abusively use, in particular reproduction and dissemination to third parties is not permitted. You can be punished by civil law. Technical changes are reserved.

				Date	Name	
				Draw.	14.04.2020	SL
				Appr.	14.04.2020	KH
				Norm		2:1
				Scale:		
				Material:		
B	RST-Logo+New Model	15.05.2024	SL	Polyamid		Drawing-Nr.: 1x08x512HLD_SZM_TD_German
A	Text	09.11.2020	SL			
Status	Modification	Date	Name	Z:\Inventor\Montageanleitung\Druckausgleichselemente\UL-DAE_Kunststoff\M_1x08x512HLD\UL-DAE-01-1-BG-0001-1x08x512HLD_SZM_TD_German.idw		A4
						V12

Bitte beachten Sie, dass es sich bei der o.a. Darstellung nur um ein Maßbild handelt.

Mounting Instruction

Threaded Enclosure
O-Ring Application

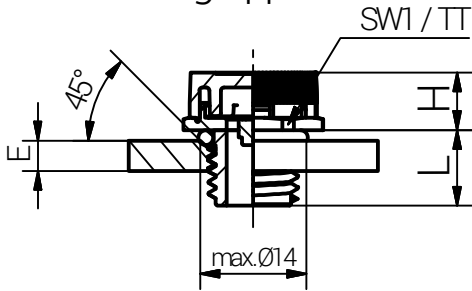

E= Min. 4,0 mm
O-Ring

Non Threaded Enclosure
O-Ring Application

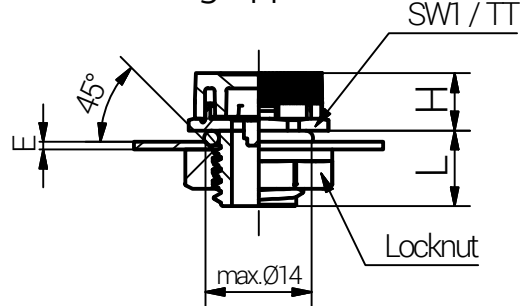

E= Max. 1,0 mm für 6,0 mm plug thread length
E= Max. 5,0 mm für 10,0 mm plug thread length

Step	Assembly Steps (The installation should only be done by a qualified Electricians who are trained in the installation of cable glands.)																																
1	Mount the pressure balance element with the connection thread on the counterpart (e.g. electronic enclosure) and tighten until the O-Ring fulfills its function. Over tightening may cause damage.																																
The pressure equalization element should be mounted laterally.																																	
	<table border="1"> <thead> <tr> <th colspan="2">Articel</th> <th>Type of membrane</th> <th>Thread</th> <th>SW1</th> <th>L</th> <th>H max.</th> <th>Tighting Torque (Nm) TT</th> </tr> <tr> <th>RAL7035</th> <th>RAL9005</th> <th></th> <th>G</th> <th>(mm)</th> <th>(mm)</th> <th>(mm)</th> <th>Tolerances ±0,1</th> </tr> </thead> <tbody> <tr> <td>11086512HLD</td> <td>13086512HLD</td> <td>H</td> <td>M12x1,5</td> <td>17</td> <td>6,0</td> <td>7,6</td> <td>0,5</td> </tr> <tr> <td>11087512HLD</td> <td>13087512HLD</td> <td>H</td> <td>M12x1,5</td> <td>17</td> <td>10,0</td> <td>7,6</td> <td>0,5</td> </tr> </tbody> </table>	Articel		Type of membrane	Thread	SW1	L	H max.	Tighting Torque (Nm) TT	RAL7035	RAL9005		G	(mm)	(mm)	(mm)	Tolerances ±0,1	11086512HLD	13086512HLD	H	M12x1,5	17	6,0	7,6	0,5	11087512HLD	13087512HLD	H	M12x1,5	17	10,0	7,6	0,5
Articel		Type of membrane	Thread	SW1	L	H max.	Tighting Torque (Nm) TT																										
RAL7035	RAL9005		G	(mm)	(mm)	(mm)	Tolerances ±0,1																										
11086512HLD	13086512HLD	H	M12x1,5	17	6,0	7,6	0,5																										
11087512HLD	13087512HLD	H	M12x1,5	17	10,0	7,6	0,5																										



RST Rabe-System-Technik und Vertriebs-GmbH
Otto-Lilienthal-Strasse 19
49134 Wallenhorst
☎ +49 5407 8766-0
☎ +49 5407 8766-99
✉ info@rst.eu

Unless otherwise specified on the drawing:
Metric Thread = EN 60423
PG Thread = DIN 40430
NPT Thread = ANSI B1.20.1
Tolerance: DIN ISO 2768-m
All dimensions in mm

Abusively use, in particular reproduction and dissemination to third parties is not permitted. You can be punished by civil law. Technical changes are reserved.

				Date	Name	<h2>UL-Pressure Balance Elements M</h2>
			Draw.	14.04.2020	SL	
			Appr.	14.04.2020	KH	
			Norm		2:1	
			Scale:			
			Material:		Polyamide	Drawing-Nr.:
						1x08x512HLD_SZM_TD_Englisch
B	RST-Logo+New Model	15.05.2024	SL			1 of 1
A	Text	09.11.2020	SL			A4
Status	Modification	Date	Name	Z:\Inventor\Montageanleitung\Druckausgleichselemente\UL-DAE_Kunststoff\LM_1x08x512HLD\UL-DAE-01-1-BG-0001-1x08x512HLD_SZM_TD_Englisch.idw		V12

Please note that the above representation is just a dimension illustration.