

Montageanleitung

Gewindebohrung
mit Flachdichtung

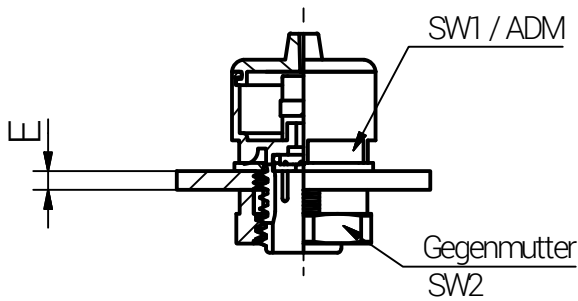

Durchgangsbohrung
mit Flachdichtung

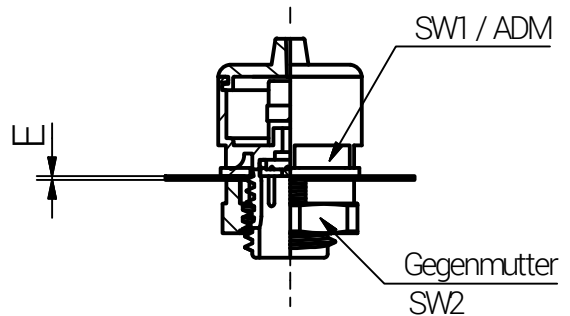

Schritt	Montageschritt (Die Installation sollte nur von einem qualifizierten Elektriker durchgeführt werden, der in der Installation von Kabelverschraubungen geschult ist.)
1	Entwässerungselement mit dem Anschlussgewinde am Gegenstück (z.B. Elektronikgehäuse) montieren und soweit anziehen, dass die Flachdichtung ihre Funktion erfüllt. Als Richtwert gilt der in der Tabelle genannte ADM. Zu festes Anziehen kann zu Beschädigungen führen.

Entwässerungsstutzen sollte an die tiefste Stelle montiert werden.

Artikel			Luft- durchlass l/h	Wasser- durchlass l/h	Gewinde	SW1 (mm)	SW2 (mm)	L (mm)	H (mm)	D (mm)	Anzugsdrehmoment (Nm) ADM Toleranz ±0,1
RAL7035	RAL7001	RAL9005			AG						
11088512DP	12088512DP	13088512DP	252	18±0,3	M12x1,5	17	18	12,0	17,5	19,0	0,5



RST Rabe-System-Technik und Vertriebs-GmbH
Otto-Lilienthal-Strasse 19
49134 Wallenhorst
☎ +49 5407 8766-0
☎ +49 5407 8766-99
✉ info@rst.eu

Unless otherwise specified on the drawing:
Metric Thread = EN 60423
PG Thread = DIN 40430
NPT Thread = ANSI B1.20.1
Tolerance: DIN ISO 2768-m
All dimensions in mm

Abusively use, in particular reproduction and dissemination to third parties is not permitted. You can be punished by civil law. Technical changes are reserved.

				Date	Name	<h2>Mini-Entwässerungsstutzen M12x1,5</h2>					
				Draw.	02.11.2020					SL	
				Appr.	02.11.2020					KH	
				Norm						1:1	
				Scale:							
				Material:		Polyamid	Drawing-Nr.:		1x088512DP_SZM_TD_German	1	of 1
									A4		
Status	Modification	Date	Name	Z:\Inventor\Montageanleitung\Druckausgleichselemente\Mini-Entwässerungsstutzen\EWS-1x088512DP_SZM_TD_German.idw							V12

Bitte beachten Sie, dass es sich bei der o.a. Darstellung nur um ein Maßbild handelt.

Mounting Instruction

Threaded Enclosure
with Flat Sealing Washer

Non Threaded Enclosure
with Flat Sealing Washer

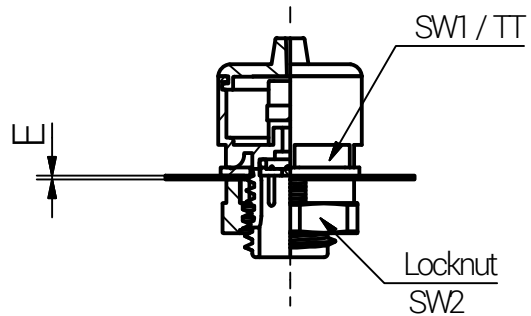
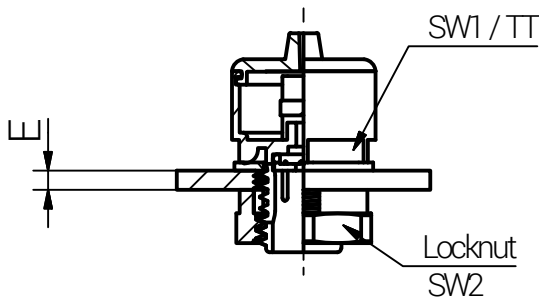

Step	Assembly Steps (The installation should only be done by a qualified electrician who are trained in the installation of cable glands.)
1	Mount the drain plug with the connection thread on the counterpart (e.g. electronic enclosure) and tighten until the washer fulfills its function. The guiding value is the TT mentioned in the table. Over tightening may cause damage.

The pressure equalization element should be mounted at the lowest point.

Article			Air Flow	Water Flow Rate	Thread	SW1	SW2	L	H	D	Tightening Torque (Nm) TT
RAL7035	RAL7001	RAL9005	l/h	l/h	AG	(mm)	(mm)	(mm)	(mm)	(mm)	Tolerance ±0,1
11088512DP	12088512DP	13088512DP	252	18±0,3	M12x1,5	17	18	12,0	17,5	19,0	0,5



RST Rabe-System-Technik und Vertriebs-GmbH
Otto-Lilienthal-Strasse 19
49134 Wallenhorst
☎ +49 5407 8766-0
☎ +49 5407 8766-99
✉ info@rst.eu

Unless otherwise specified on the drawing:
Metric Thread = EN 60423
PG Thread = DIN 40430
NPT Thread = ANSI B1.20.1
Tolerance: DIN ISO 2768-m
All dimensions in mm

Abusively use, in particular reproduction and dissemination to third parties is not permitted. You can be punished by civil law. Technical changes are reserved.

				Date	Name	<h2 style="margin: 0;">MINI DRAIN PLUG</h2> <h3 style="margin: 0;">M12x1,5</h3>					
				Draw.	02.11.2020					SL	
				Appr.	02.11.2020					KH	
				Norm						1:1	
				Scale:							
				Material:		Polyamide	Drawing-Nr.:		1x088512DP_SZM_TD_Englisch	1	of 1
									A4		
Status	Modification	Date	Name	Z:\inventor\Montageanleitung\Druckausgleichselemente\Mini-Entwässerungsstutzen\EWS-1x088512DP_SZM_TD_Englisch.idw							V7

Please note that the above representation is just a dimension illustration.