

Montageanleitung

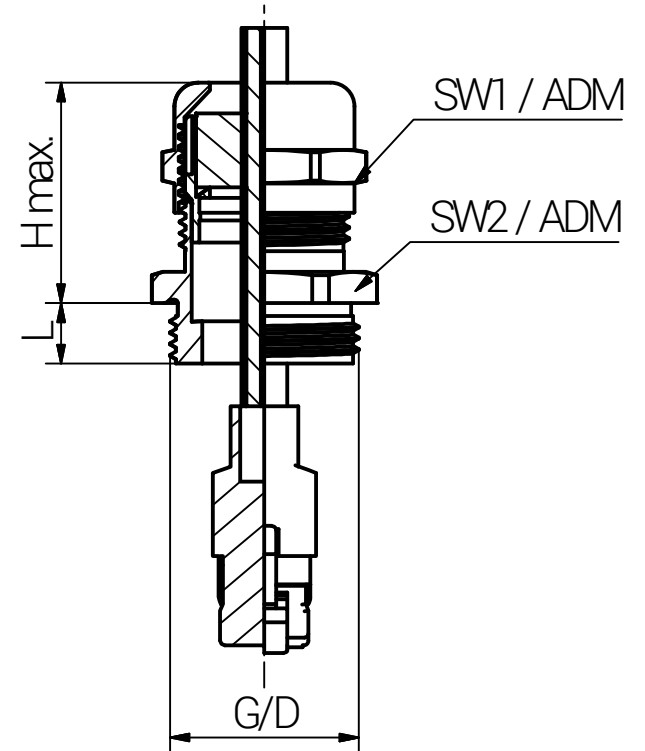

Schritt	Montageschritt (Die Installation sollte nur von einem qualifizierten Elektriker durchgeführt werden, der in der Installation von Kabelverschraubungen geschult ist.)
1	Kabelverschraubung mit dem Anschlussgewinde am Gegenstück (z.B. Elektronikgehäuse) montieren.
2	Stutzen soweit anziehen, dass der O-Ring seine Funktion erfüllt. Zu festes Anziehen kann zu Beschädigungen führen.
3	Kabel durch die Kabelverschraubungen führen.
4	Hutmutter soweit anziehen, dass der Dichteinsatz seine Funktion erfüllt. Zu festes Anziehen kann zu Beschädigungen führen.
Durchmesser des Montagelochs: - Gewindebohrung gemäß EN 60423 - Durchgangsbohrung siehe Tabelle.	
IP-Schutzart ist IP 68 (5 bar / 30 min.) / IP 66* / IP 69k. *Mit Flachdichtung	
Einsatztemperatur: -20°C bis + 100°C	

Artikel		Gewinde	Klemmbereich (mm)		SW1 (mm)	SW2 (mm)	L (mm)	H max. (mm)	Durchgangsbohrung D (mm)	Anzugsdrehmoment (Nm) ADM	
MS	1.4305	G	≥	≤					Hutmutter	Stutzen	
60580532		M32x1,5	3,0	6,0	30	34	9,0	33,0	32 (0/+0,2)	20,0	6,0
	90580532	M32x1,5	3,0	6,0	30	36	9,0	41,5	32 (0/+0,2)	20,0	6,0

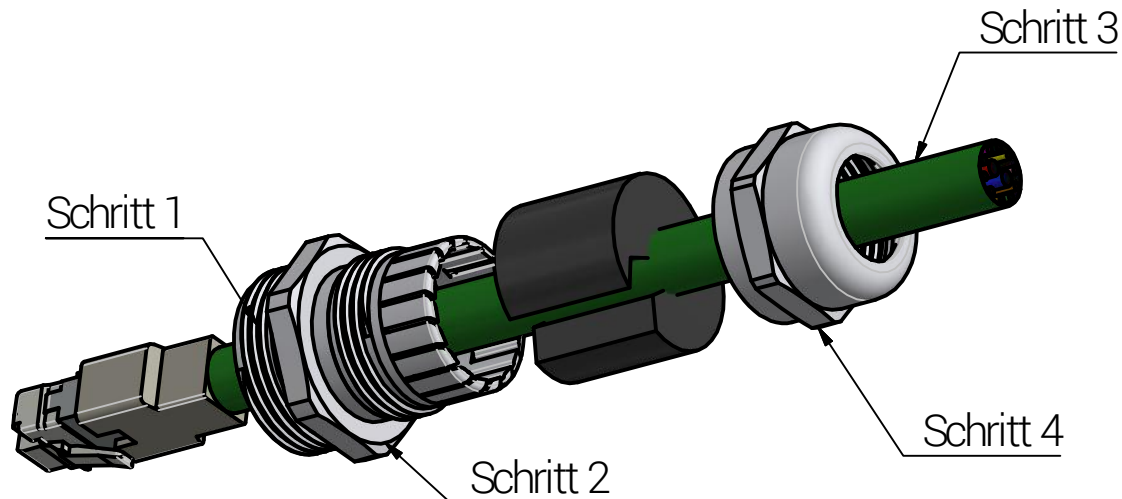

RST Rabe-System-Technik und Vertriebs-GmbH
Otto-Lilienthal-Strasse 19
49134 Wallenhorst
☎ +49 5407 8766-0
☎ +49 5407 8766-99
✉ info@rst.eu

Unless otherwise specified on the drawing:
Metric Thread = EN 60423
PG Thread = DIN 40430
NPT Thread = ANSI B1.20.1
Tolerance: DIN ISO 2768-m
All dimensions in mm.

Abusively use, in particular reproduction and dissemination to third parties is not permitted. You can be punished by civil law. Technical changes are reserved.

		Date	Name
Draw.		29.10.2020	SL
Appr.		29.10.2020	KH
Norm			
Scale:			1:1
C			
B			
A	Anzugsdrehmoment	10.05.2021	SL
Status	Modification	Date	Name

Material: Messing, vern. / Edelstahl

Euro-Top CONNECT Metall Metrisch

Drawing-Nr.:	x0580532_SZM_TD_German	1	of 1
		A4	
		V9	

Mounting Instruction

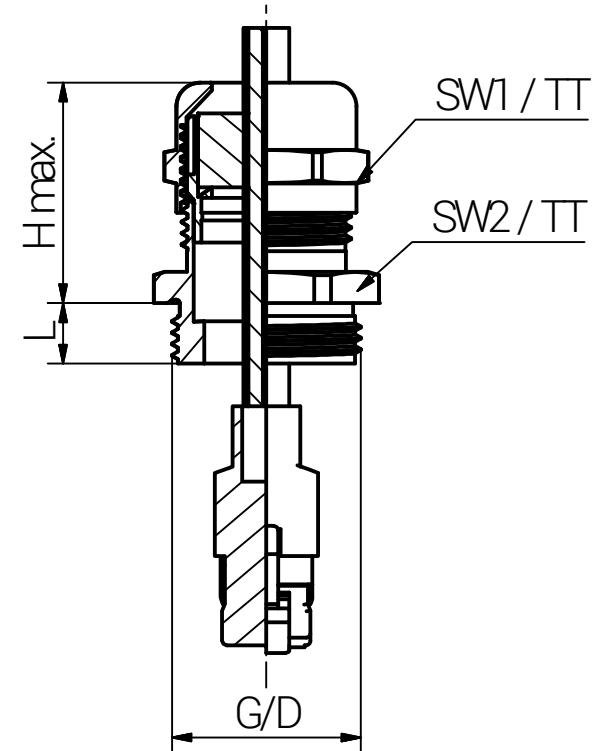
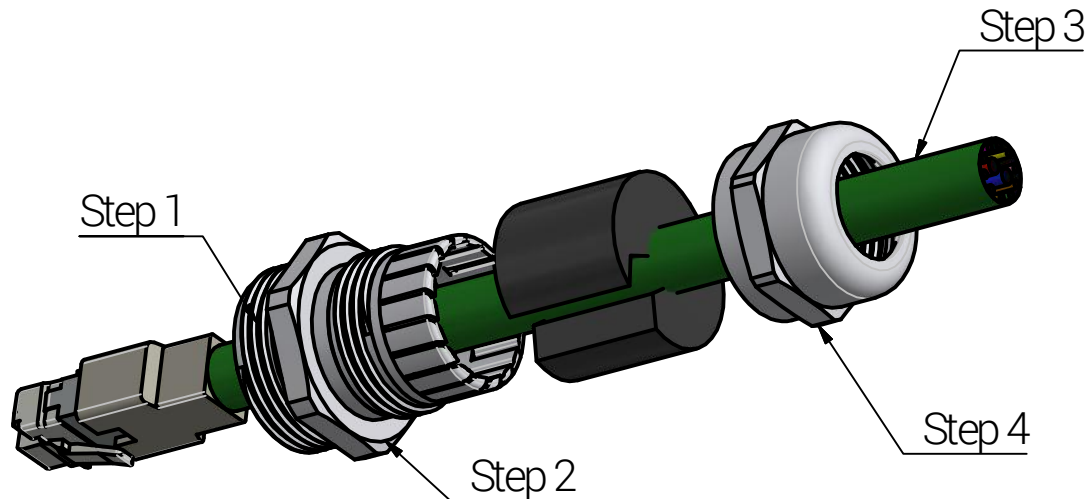

Step	Assembly Steps (The installation should only be done by a qualified electrician who are trained in the installation of cable glands.)
1	Mount the cable gland with the connection thread on the counterpart (e.g. electronic enclosure).
2	Tighten the body until the O-Ring fulfills its function. Over tightening may cause damage.
3	Pass the cable through the cable gland.
4	Tighten the cap until the seal fulfills its function. Over tightening may cause damage.
Diameter of the mounting hole: - Threaded hole according to EN 60423 - Through hole see table.	
Protection Class: IP 68 / IP 66* / IP 69k * With Flat Sealing Washer.	
Operating Temperature: -20°C to +100°C	

Article		Thread	Clamping Range (mm)		SW1 (mm)	SW2 (mm)	L (mm)	H max. (mm)	Non Threaded Enclosure D (mm)	Tightening Torque (Nm) TT	
BR	303	G	≥	≤					Cap	Body	
60580532		M32x1,5	3,0	6,0	30	34	9,0	33,0	32 (0/+0,2)	20,0	6,0
	90580532	M32x1,5	3,0	6,0	30	36	9,0	41,5	32 (0/+0,2)	20,0	6,0



RST Rabe-System-Technik und Vertriebs-GmbH
Otto-Lilienthal-Strasse 19
49134 Wallenhorst
☎ +49 5407 8766-0
☎ +49 5407 8766-99
✉ info@rst.eu

Unless otherwise specified on the drawing:
Metric Thread = EN 60423
PG Thread = DIN 40430
NPT Thread = ANSI B1.20.1
Tolerance: DIN ISO 2768-m
All dimensions in mm.

Abusively use, in particular reproduction and dissemination to third parties is not permitted. You can be punished by civil law. Technical changes are reserved.

		Date	Name
Draw.		29.10.2020	SL
Appr.		29.10.2020	KH
Norm			
Scale:			1:1
Material:			
			Nickel Plated Brass / Stainless Steel
A	Tightening Torque	10.05.2021	SL
Status	Modification	Date	Name

Euro-Top CONNECT Metal Metric

Drawing-Nr.:	x0580532_SZM_TD_Englisch	1	of 1
		A4	
		V7	

Please note that the above representation is just a dimension illustration.