

# Montageanleitung

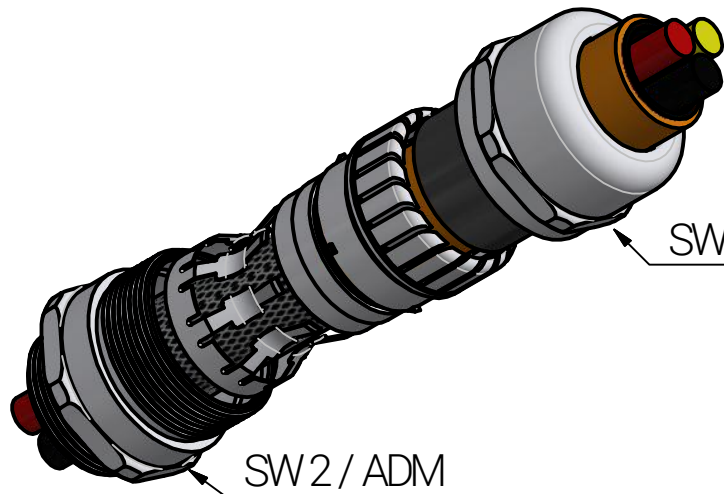

SW 1 / ADM

Schritt 3

SW 2 / ADM

Schritt 1  
Schritt 2

Schritt 4

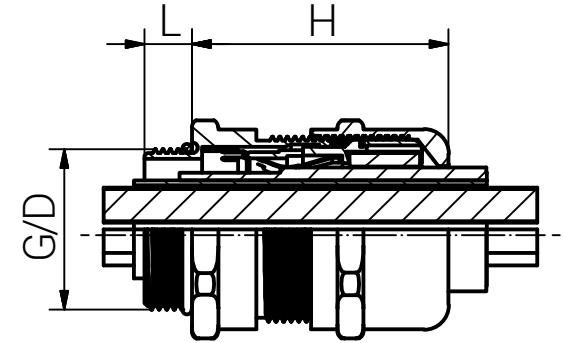

Schritt	Montageschritt (Die Installation sollte nur von einem qualifizierten Elektriker durchgeführt werden, der in der Installation von Kabelverschraubungen geschult ist.)
1	Kabelverschraubung mit dem Anschlussgewinde am Gegenstück (z.B. Elektronikgehäuse) montieren.
2	Stützen soweit anziehen, dass der O-Ring seine Funktion erfüllt. Als Richtwert gilt der in der Tabelle genannte ADM. Zu festes Anziehen kann zu Beschädigungen führen.
3	Kabel vorbereiten (abmanteln) und durch die Kabelverschraubungen führen, so dass das EMV-Element der Kabelverschraubung und die Schirmung des Kabels kontaktiert werden können.
4	Hutmutter soweit anziehen, dass der Dichteinsatz seine Funktion erfüllt und das EMV-Element und die Schirmung Kontakt haben. Zu festes Anziehen kann zu Beschädigungen führen.
Durchmesser des Montagelochs: - Gewindebohrung gemäß EN 60423 - Durchgangsbohrung siehe Tabelle.	
Zugentlastung gemäß EN 62444: 2013 - Klemmbereich 3-4 mm = Rückhaltevermögen - Rest = Kategorie A	
IP-Schutzart ist IP 68 (5 bar / 30 min.) / IP 66.	
Einsatztemperatur: -40°C bis +100°C	

Artikel	Gewinde G	Klemmbereich (mm)		Klemmbereich Schirm (mm)		SW1 (mm)	SW2 (mm)	L (mm)	H max. (mm)	D (mm)	Durchgangs- bohrung (mm)	Anzugsdreh- moment (Nm) ADM		Kategorie der Schlägein- wirkung
		≥	≤	≥	≤							Hutmutter	Stützen	
R61086512	M12x1,5	3,0	6,5	2,0	5,0	14	14	6,0	30,0	12,0	12 (0/+0,2)	5,0	5,0	2
R61086516	M16x1,5	5,0	10,0	3,5	8,0	20	20	6,0	35,0	16,0	16 (0/+0,2)	6,0	6,0	2
R61086520	M20x1,5	6,0	12,0	4,5	10,0	22	22	6,0	33,5	20,0	20 (0/+0,2)	6,0	6,0	2
R61086522	M20x1,5	7,5	14,0	5,5	11,5	24	24	8,0	41,5	20,0	20 (0/+0,2)	10,0	6,0	-
R61086525	M25x1,5	10,0	18,0	7,0	14,0	30	30	8,0	44,5	25,0	25 (0/+0,2)	15,0	6,0	4
R61086532	M32x1,5	16,0	25,0	12,0	20,0	40	40	9,0	55,0	32,0	32 (0/+0,2)	22,0	6,0	4
R61086540	M40x1,5	22,0	32,0	18,0	27,0	50	50	9,0	62,5	40,0	40 (0/+0,2)	42,0	12,0	4



RST Rabe-System-Technik und Vertriebs-GmbH  
Otto-Lilienthal-Strasse 19  
49134 Wallenhorst  
☎ +49 5407 8766-0  
☎ +49 5407 8766-99  
✉ info@rst.eu

Unless otherwise specified on the drawing:  
Metric Thread = EN 60423  
PG Thread = DIN 40430  
NPT Thread = ANSI B1.20.1  
Tolerance: DIN ISO 2768-m  
All dimensions in mm.

Abusively use, in particular reproduction and dissemination to third parties is not permitted. You can be punished by civil law. Technical changes are reserved.

Date		Name	
Draw.	16.11.2021	SL	
Appr.	16.11.2021	KH	
Norm			
Scale:		1:1,5	
Material:		Messing, vern.	
Status	Modification	Date	Name

## Euro-Top EMV / Metrisch Bahnanwendungen (4. Generation)

Drawing-Nr.:	R610865xx_SZM_TD_German	1	of 1
		A4	V7

# Mounting Instruction

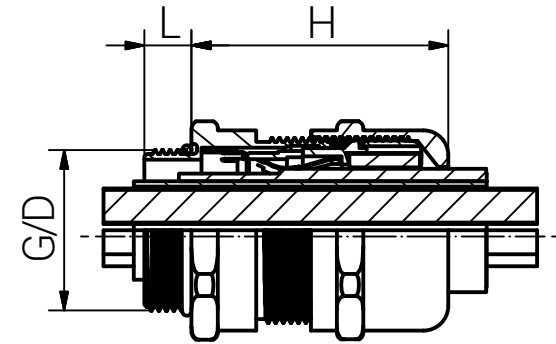
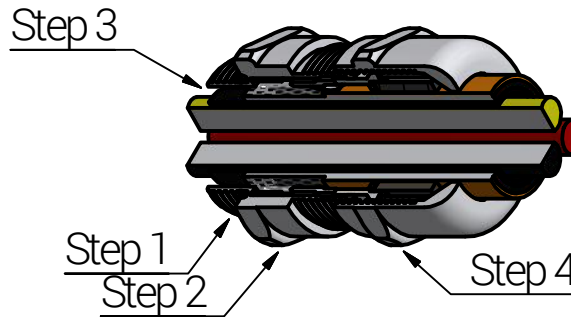
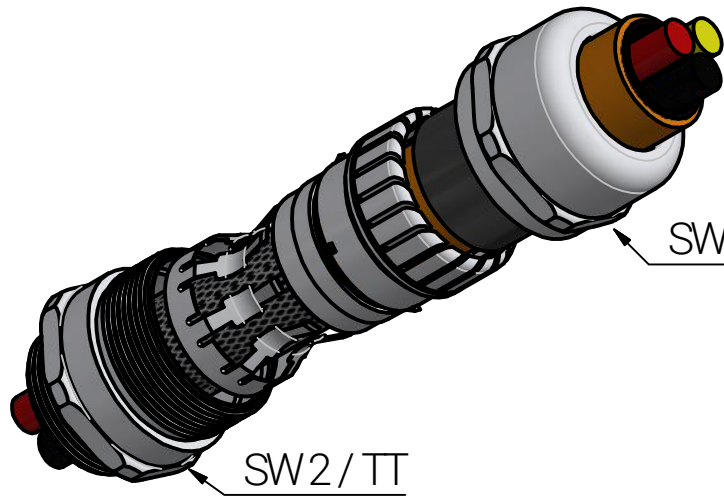

Article	Thread G	Clamping Range (mm)		Shield Diameter (mm)		SW1 (mm)	SW2 (mm)	L (mm)	H max. (mm)	D (mm)	Non Threaded Enclosure (mm)	Tightening Torque (Nm) TT		Impact Category
		≥	≤	≥	≤							Cap	Body	
R61086512	M12x1,5	3,0	6,5	2,0	5,0	14	14	6,0	30,0	12,0	12 (0/+0,2)	5,0	5,0	2
R61086516	M16x1,5	5,0	10,0	3,5	8,0	20	20	6,0	35,0	16,0	16 (0/+0,2)	6,0	6,0	2
R61086520	M20x1,5	6,0	12,0	4,5	10,0	22	22	6,0	33,5	20,0	20 (0/+0,2)	6,0	6,0	2
R61086522	M20x1,5	7,5	14,0	5,5	11,5	24	24	8,0	41,5	20,0	20 (0/+0,2)	10,0	6,0	-
R61086525	M25x1,5	10,0	18,0	7,0	14,0	30	30	8,0	44,5	25,0	25 (0/+0,2)	15,0	6,0	4
R61086532	M32x1,5	16,0	25,0	12,0	20,0	40	40	9,0	55,0	32,0	32 (0/+0,2)	22,0	6,0	4
R61086540	M40x1,5	22,0	32,0	18,0	27,0	50	50	9,0	62,5	40,0	40 (0/+0,2)	42,0	12,0	4

Step	Assembly Steps (The installation should only be done by a qualified electrician who are trained in the installation of cable glands.)
1	Mount the cable gland with the connection thread on the counterpart (e.g. electronic enclosure).
2	Tighten the body until the O-Ring fulfills its function. The guiding value is the TT mentioned in the table. Over tightening may cause damage.
3	Prepare the cable (dismantle) and pass it through the cable gland so that the EMC element of the cable gland and the shielding of the cable can be contacted.
4	Tighten the cap until the seal fulfills its function and that the EMC element and the shielding are in contact. Over tightening may cause damage.
Diameter of the mounting hole: - Threaded hole according to EN 60423 - Through hole see table.	
Type of cable anchorage according to EN62444:2013 - Clamping range 3-4mm = cable retention - Balance = Category A	
Degree of protection: IP 68 (5 bar / 30 min.) / IP 66.	
Operating Temperature: -40°C to +100°C	



RST Rabe-System-Technik und Vertriebs-GmbH  
 Otto-Lilienthal-Strasse 19  
 49134 Wallenhorst  
 ☎ +49 5407 8766-0  
 📠 +49 5407 8766-99  
 ✉ info@rst.eu

Unless otherwise specified on the drawing:  
 Metric Thread = EN 60423  
 PG Thread = DIN 40430  
 NPT Thread = ANSI B1.20.1  
 Tolerance: DIN ISO 2768-m  
 All dimensions in mm.

Abusively use, in particular reproduction and dissemination to third parties is not permitted. You can be punished by civil law. Technical changes are reserved.

Date	Name
Draw. 16.11.2021	SL
Appr. 16.11.2021	KH
Norm	
Scale:	1:1,5
Material:	Nickel Plated Brass
Status	Modification
Date	Name

Euro-Top EMC / Metric Rail Application (4th Generation)		Drawing-Nr.:	R610865xx_SZM_TD_English	1	of 1
				A4	V7